

HIGH FINSEAL WEATHERSTRIP SEALS (HF)

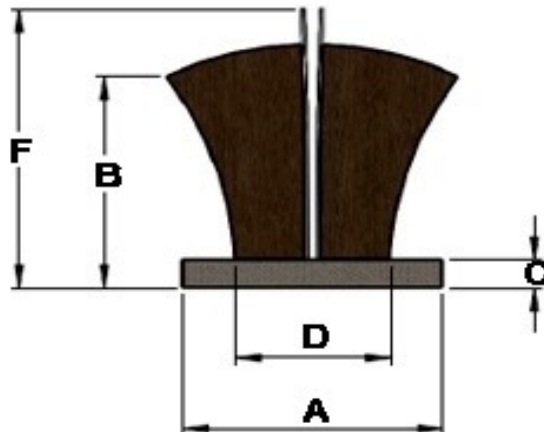

A. Base Width	-	(3.2 to 85mm) Tolerance $\pm 0.1\text{mm}$
B. Pile Height	-	(03 to 20mm) Tolerance -0.1 to + 0.5mm
C BASE THICKNESS	-	$0.8 \pm 0.15\text{mm}$
D PILE WIDTH	-	4.8 base – $2.5\text{mm} \pm 0.5\text{mm}$, 6.7 base – $3.0 \text{mm} \pm 0.5\text{mm}$
HF	-	The height of the fin is higher than the pile, +1.5 to 2.5mm



PILE DENSITY	-	2P TO 8P
STANDARD PACKING	-	170 – 350 METER / ROLL
		510 – 900 METER/ CARTON

ALUMINIUM GROOVE INDICATOR FOR BRUSH SELECTION

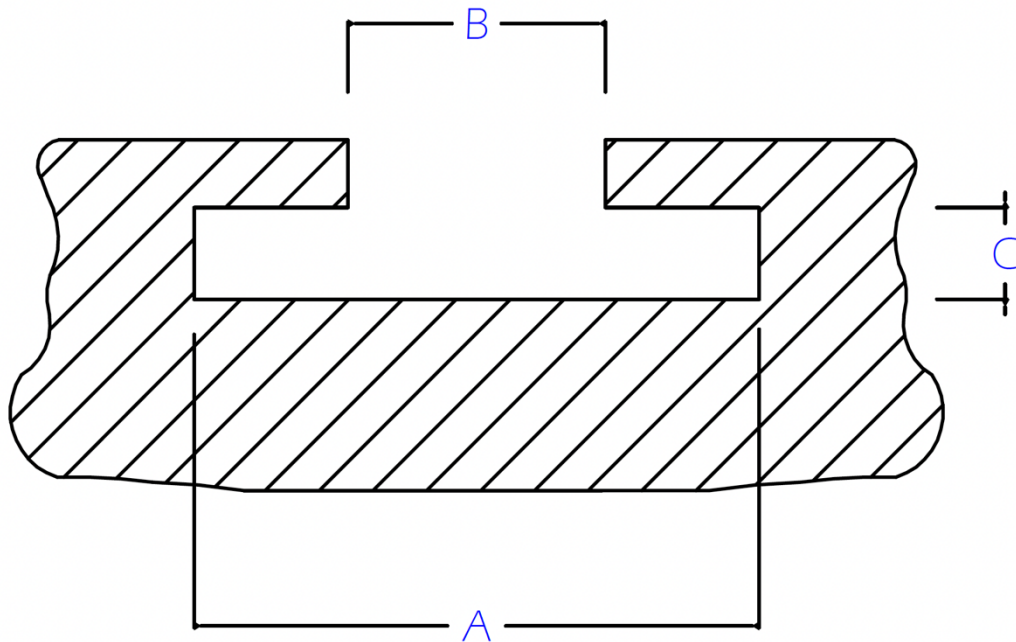

ALUMINIUM GROOVE INDICATOR FOR BRUSH SELECTION

A is groove width = Brush base width +0.4 to +0.8mm

C is groove depth = 1.2 ± 0.1 mm