

STANDARD WEATHERSTRIP SEALS

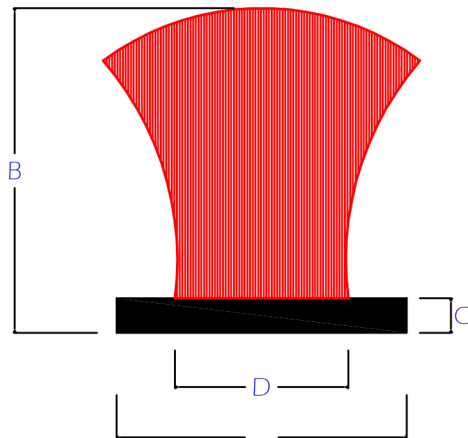

- A. BASE WIDTH** - (3.2 to 85mm) Tolerance $\pm 0.1\text{mm}$
- B. PILE HEIGHT** - (03 to 20mm) Tolerance -0.1 to $+ 0.5\text{mm}$
- C. BASE THICKNESS** - $0.75 \pm 0.15\text{mm}$
- D. PILE WIDTH** - 4.8 base – $2.5\text{mm} \pm 0.5\text{mm}$. 6.7 base – $3.0 \text{mm} \pm 0.5\text{mm}$



- PILE DENSITY** - 2P TO 60P
- STANDARD PACKING** - 250 – 500 METER / ROLL
1000 – 2000 METER / CARTON

ALUMINIUM GROOVE INDICATOR FOR BRUSH SELECTION

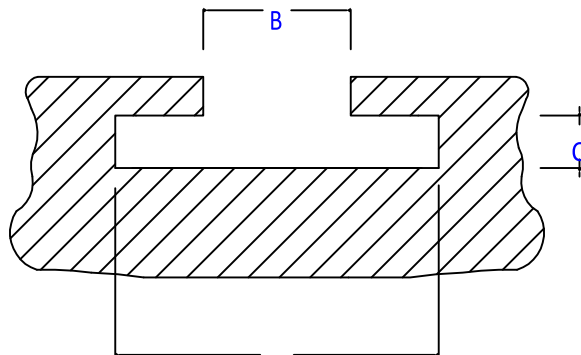

A is groove width = Brush base width $+0.4$ to $+0.8\text{mm}$

C is groove depth = $1.2 \pm 0.1\text{mm}$